

TECHNICAL INFORMATION SHEET

PART NUMBERS: **1428 / 1432 / 1544 / 1555 / 1556 / 1557**



1428
The same as 1432
without cover

1432

1544
The same as 1556
without cover

1555
The same as 1557
Without cover

1556

1557

Example of a cooling system from a Fiat Bravo - Brava 1.6 Gasoline (PN. 1556)

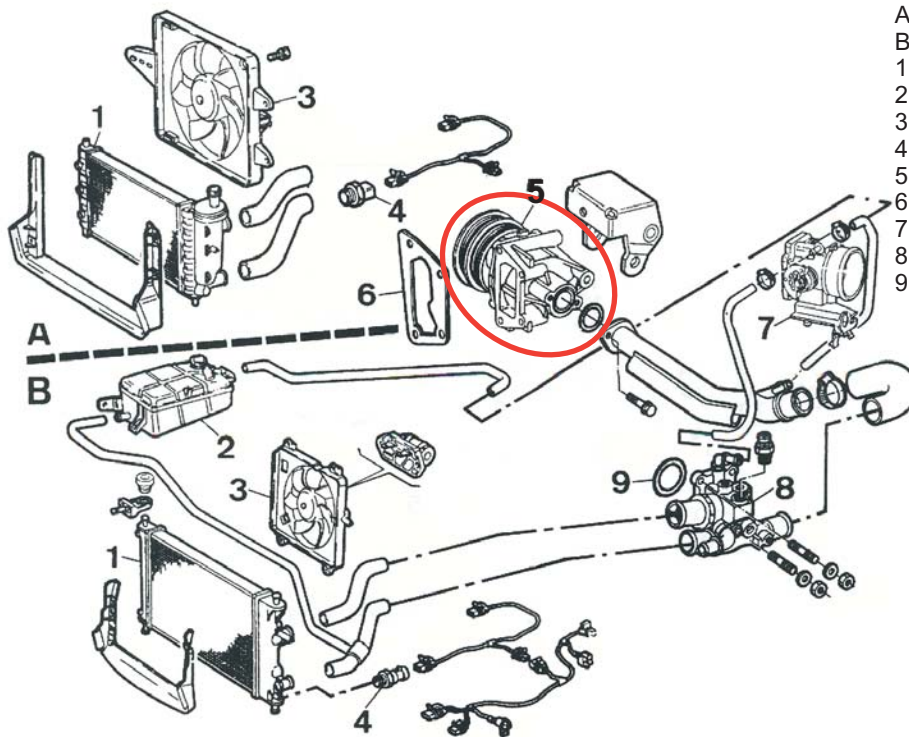

- A. Without air conditioning
- B. With air conditioning
- 1. Radiator
- 2. Expansion jar
- 3. Fan engine
- 4. Temperature switch
- 5. **Water pump**
- 6. Water pump gasket
- 7. Throttle cover
- 8. Thermostat housing
- 9. O'ring

Water pump from a Lancia Delta '93 1.6

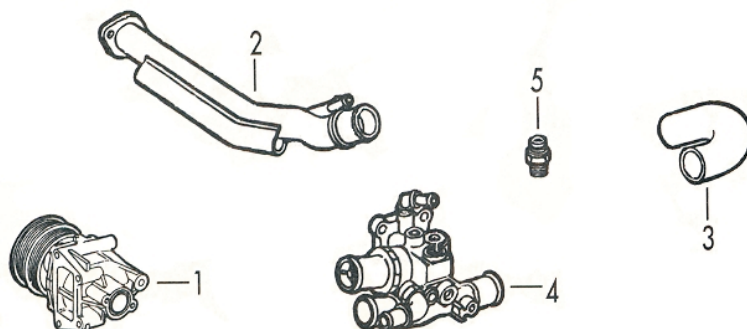

- 1. **Water pump**
- 2. Outlet pipe
- 3. Hose to thermostat
- 4. Water pump cover with thermostat
- 5. Temperature gauge

TECHNICAL INFORMATION SHEET

PART NUMBERS: **1428 / 1432 / 1544 / 1555 / 1556 / 1557**

Demounting of a water pump from a Fiat Stilo 1.6 16v. (PN: 1556)

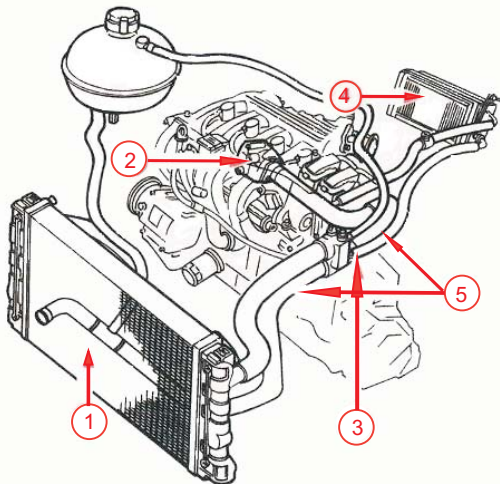

→ Cooling system

1. Cooling radiator
2. Circulating pump
3. Thermostat
4. Radiador habitáculo
5. Connection hoses

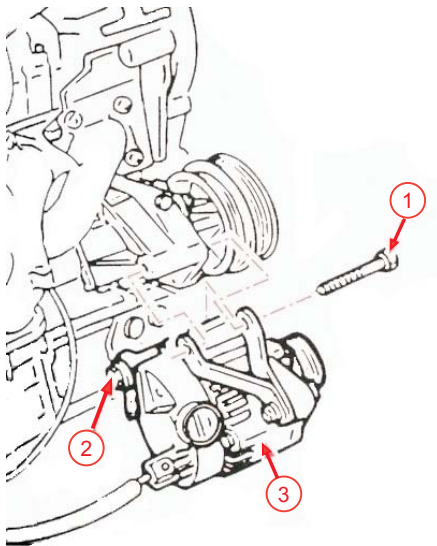

→ Demounting of the water pump

- Remove the alternator/pump belt.
1. Remove upper lock bolt (1)
 2. Unscrew the internal lock bolt
 3. Rotate the alternator down to accede to the water pump.

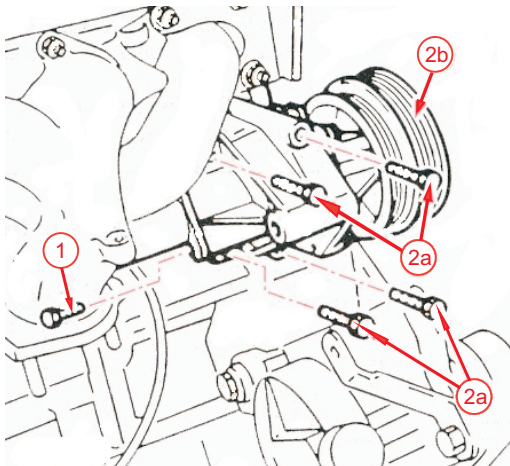

1. Remove the fixing bolts (1) of the inlet pipe in the water pump, from the water pump side.
2. Remove bolts (2a) and the water pump (2b) with support.

Torque: 2,1 - 2,6 daN.m