

TECHNICAL INFORMATION SHEET

×PART NUMBERS: **1328 / 1406 / 1614 / 1615**



1328



1406



1614



1615

NOTE: References 1328 and 1406 are similar to 1614 and 1615, but the first ones are made on die casting aluminium, and the second ones in sand.

Example of a Mercedes E 124 200-300 gasoline cooling system. 102 Engine.

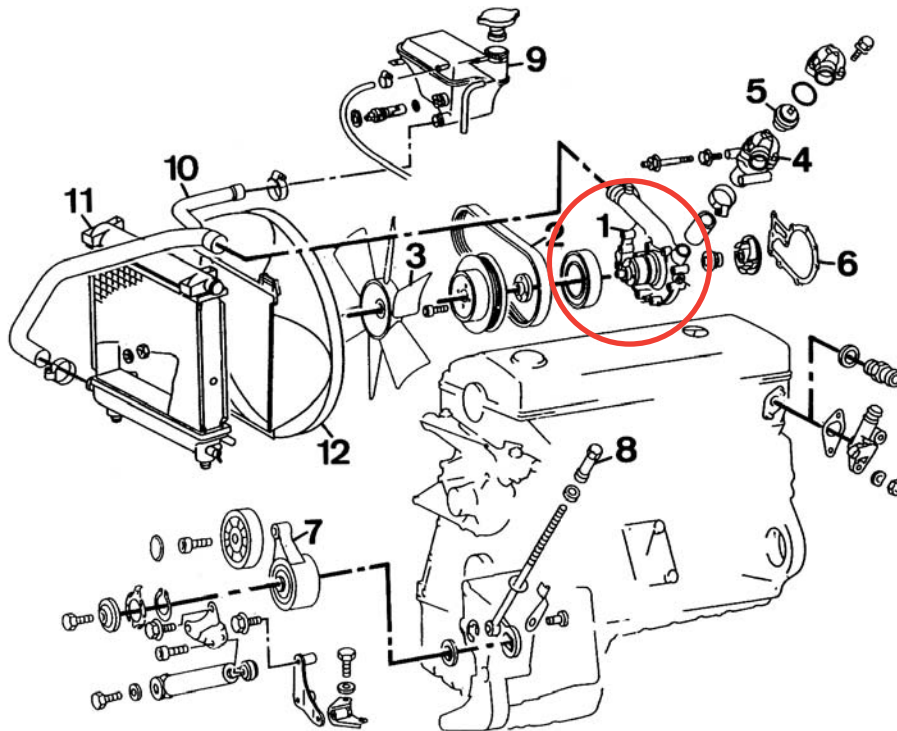

1. **Water pump**
2. Belt
3. Fan
4. Thermostatic housing
5. Thermoste
6. Gasket
7. Belt idler
8. Idler adjusting
9. Expansion jar
10. Housing
11. Radiator
12. Cover

NOTE: The water pump is located on the right side of the cylinders block and it's driven by a Micro-V belt.